

Customer Information Sheet

DRAWING No.: M80-945XX02

IF IN DOUBT - ASK

©

NOT TO SCALE

THIRD ANGLE PROJECTION

ALL DIMENSIONS IN mm

SPECIFICATIONS:

MATERIAL:
 BACKSHELL = ALUMINIUM ALLOY
 JACKSCREW & CIRCLIP = STAINLESS STEEL

FINISH:
 BACKSHELL = ELECTROLESS NICKEL

ELECTRICAL:
 RF ATTENUATION = 10kHz TO 400MHz @ >30dBs
 IN GENERAL ACCORDANCE WITH MIL STD 1377

ENVIRONMENTAL:
 TEMPERATURE RANGE = -55°C TO +125°C

PACKING:
 SEE NOTES

FOR COMPLETE SPECIFICATION, SEE COMPONENT SPECIFICATION C042XX (LATEST ISSUE)

NOTES:

- BACKSHELL IS SUPPLIER AS A KIT OF PARTS IN A BAG. BAGS WILL BE BULK PACKED INTO BOXES. NOT ASSEMBLED AS SHOWN.
- SEE INSTRUCTION SHEET IS-42 FOR ASSEMBLY DETAILS.
- TO APPLY CIRCLIPS USE HARWIN TOOL = Z80-300.
- BAND-IT TIE SOLD SEPERATELY, SEE PART NUMBERS M80-9470000 AND M80-9480000 FOR DETAILS.

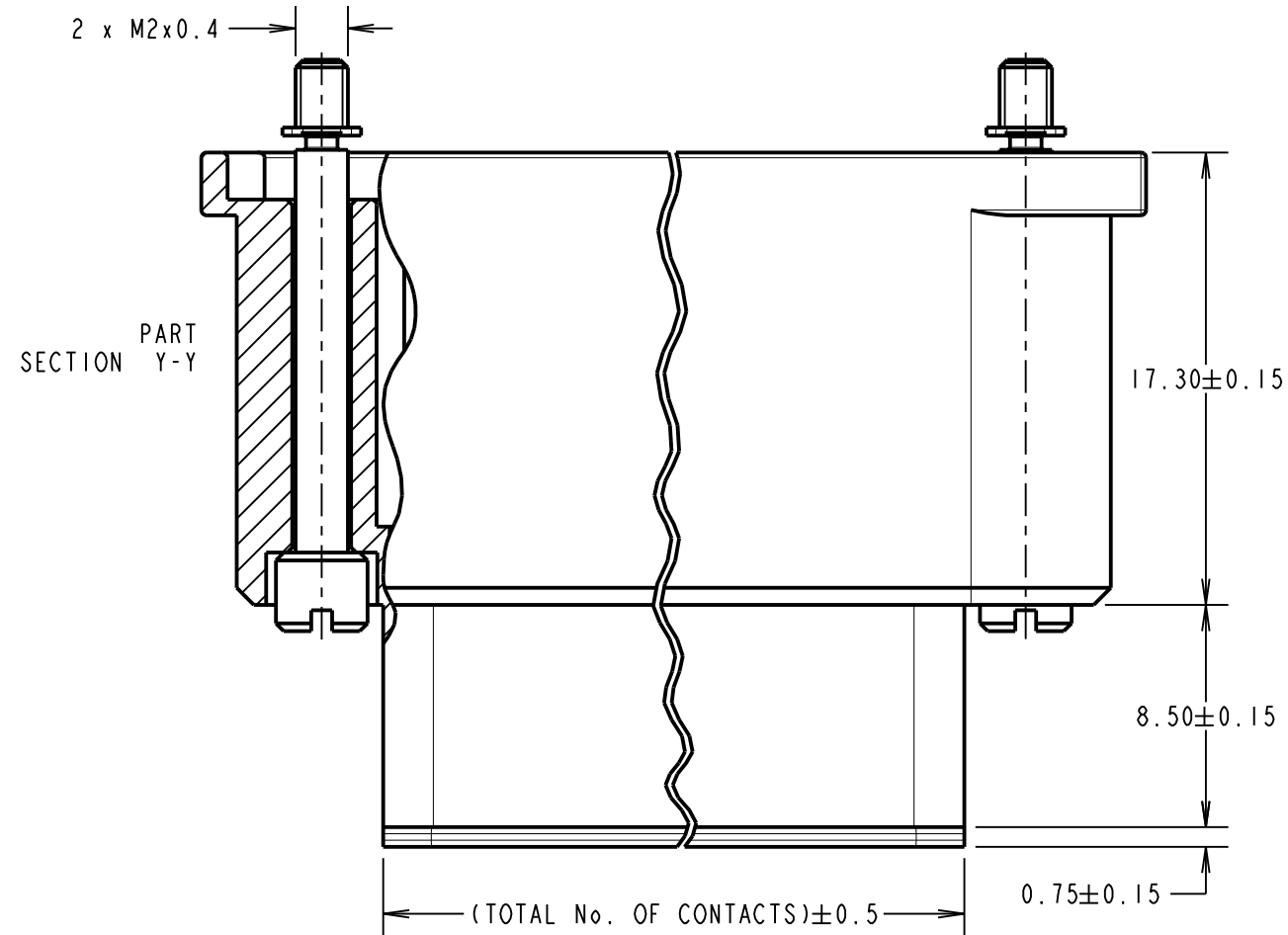
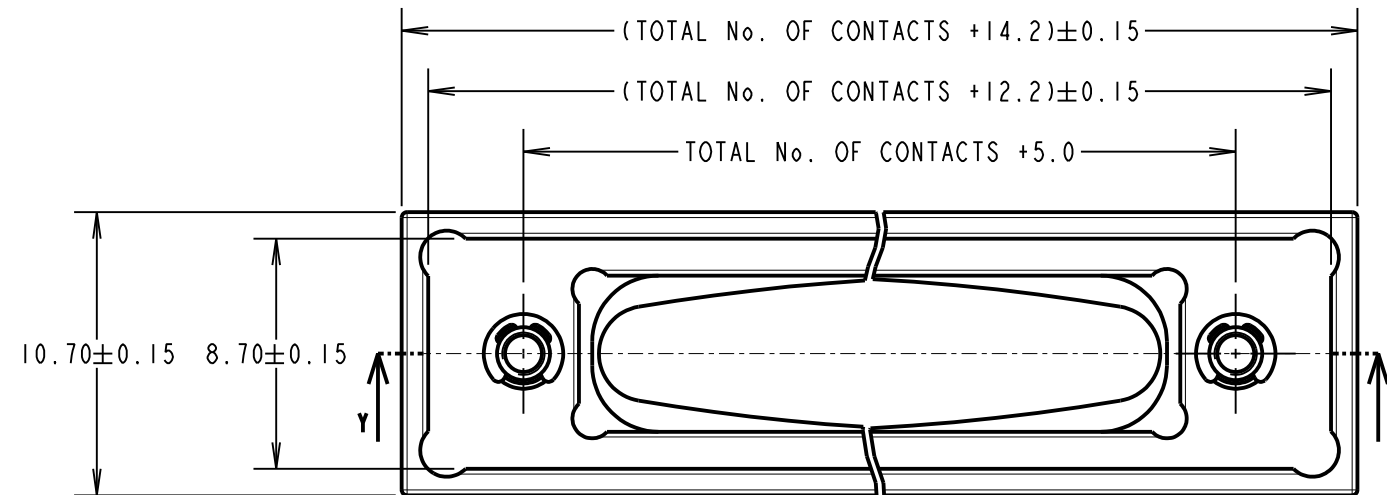

ORDER CODE:
M80-945XX02

TOTAL No. OF
 2mm PITCH CONTACTS

08, 10, 12, 14, 16, 18,
 20, 22, 24, 26, 28, 32

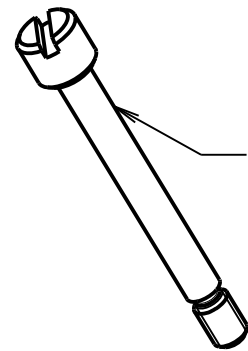

2 x M2 SLOTTED JACKSCREWS
 SUPPLIED LOOSE IN BAG

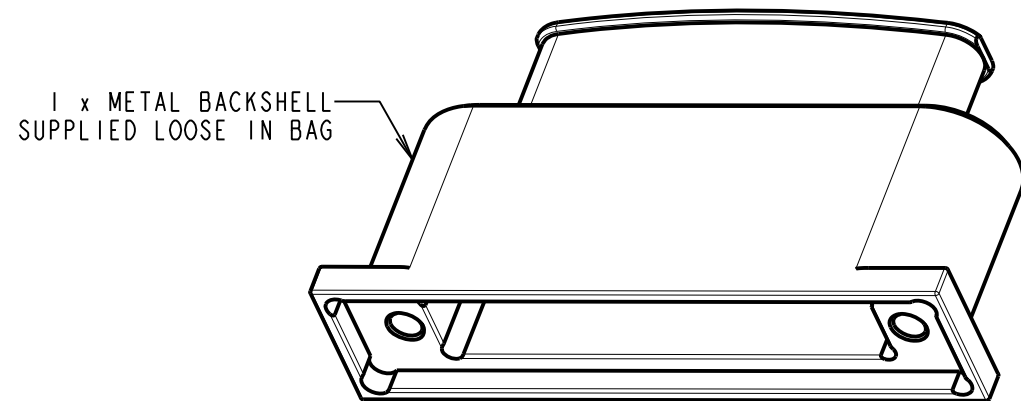

1 x METAL BACKSHELL
 SUPPLIED LOOSE IN BAG

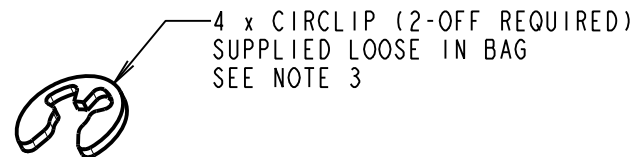

4 x CIRCLIP (2-OFF REQUIRED)
 SUPPLIED LOOSE IN BAG
 SEE NOTE 3

EXAMPLE ORDER CODE: CONNECTOR WITH
 6 x SPECIAL CONTACTS IS EQUAL TO
 24 x SIGNAL CONTACTS

M80-9452402

MGP	5	16.01.20	22207
NAME	ISS.	DATE	C/NOTE
APPROVED: MGP			
CHECKED: RP			
DRAWN: M.PERREN			
CUSTOMER REF.:			
ASSEMBLY DRG:			

 www.harwin.com technical@harwin.com	THIS DRAWING AND ANY INFORMATION OR DESCRIPTIVE MATTER SET OUT HEREON ARE CONFIDENTIAL AND COPYRIGHT PROPERTY OF THE HARWIN GROUP AND MUST NOT BE DISCLOSED, LOANED, COPIED OR USED FOR MANUFACTURING, TENDERING OR FOR ANY OTHER PURPOSE WITHOUT THEIR WRITTEN PERMISSION.	TOLERANCES X. = ±1mm X.X = ±0.50mm X.XX = ±0.20mm X.XXX = ±0.01mm ANGLES = ±5° UNLESS STATED	MATERIAL: SEE ABOVE	TITLE: DATAMATE FEMALE ASSEMBLY BACKSHELL KIT	SHT 2 OF 2
			FINISH: SEE ABOVE	DRAWING NUMBER: M80-945XX02	